

Year 4

Term 4

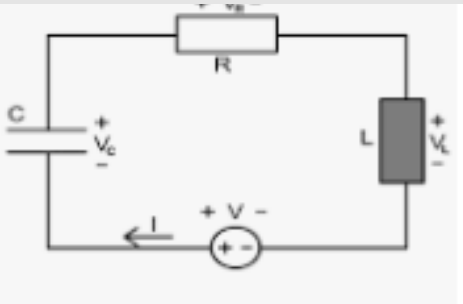

Maths

This term we will be looking at fractions : equivalence; improper fractions; and the addition and subtraction of fractions.. We are also studying decimals and we will revisit measure.

We will continue to focus on the children's recall of their multiplication tables.

Vocabulary

Multiplication, subtraction, addition, division, fraction, denominator, numerator, equivalent, decimal and measure.

Autobiography, conjunction, subordinate clause, noun phrase, main clause commas and apostrophes, standard English and word classes.

English

Over the coming term we will writing letters

We will also be studying grammar, spelling and punctuation including word classes, clauses and sentence types.

Our focus on reading will continue and we will look to further develop the children's comprehension skills.

Science

We will be learning about devices that are powered by Electricity. We will be making simple series circuits. We will learn how to explain why a bulb may not light up.



History

We will be looking at the Roman Empire and the invasion of Great Britain. We will learn about the lives of Romans and the legacy left behind by the Romans in Britain.

DT

In DT we are going to make a programmed electrical circuit to make lights come on in a model exhibition

Music

We will be learning about musical notation and singing songs.

Computing

For the next term we will be learning about E safety.

RE

We will be looking at the creation story.

PSHE

Our Jigsaw piece this term is 'Being Healthy

PE

This term Year 4 we will be studying gymnastics